

1. General Description

WP1437 can disconnect the systems from its output pin (OUT) in case wrong input operating conditions are detected.

The system is positive overvoltage protected up to 36V. The internal overvoltage thresholds (OVLO) is 10V and internal overcurrent thresholds (OCP) is 2.5A, WP1437 also has internal over temperature protect (OTP) function and it can monitor chip temperature to protect the device.

The device is packaged in advanced full-Green Packaging (SOT23-6L).

2. Features

- Typical $R_{DS(ON)}$: 110m Ω N-Channel MOSFET@5V/1A
- V_{IN} Operating Range: 3V to 36V
- Internal Overvoltage Lockout: 10V(Typ.)
- Internal Overcurrent Lockout:2.5A(MIN)
- Overvoltage-Protection Response Time: <500ns
- Startup Debounce Time: 16ms (Typ.)
- Typical Output Power on Time:16.3ms (Typ.)
- Internal Thermal-Shutdown Protection
- ESD Protected: Human Body Model: \pm 2KV JESD22-A114 (All Pins)
- SOT23-6L Package

3. Applications

- Smartphones, Tablet PC
- HDD, Storage and Solid State Memory Devices
- Portable Media Devices, Laptop & MID
- SLR Digital Cameras
- GPS and Navigation Equipment
- Industrial Handheld and Enterprise Equipment

4. Typical Application

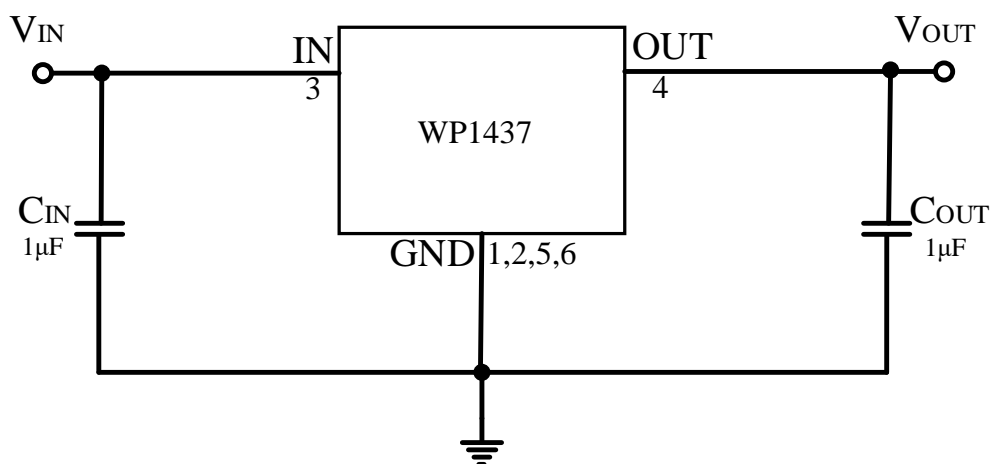

NOTE: This circuit only supplies for reference.

5. Pin Configuration

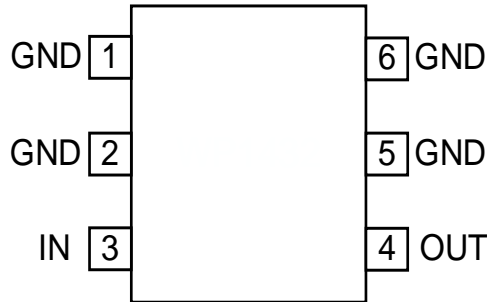

SOT23-6L

6. Pin Description

PIN NAME	PIN NUMBER	I/O	PIN FUNCTION
GND	1,2,5,6	-	Ground. All ground pins can not be floated and must be connected to GND.
IN	3	I	Switch Input.
OUT	4	O	Switch Output.

7. Absolute Maximum Ratings ^[1]

$T_A=25^{\circ}\text{C}$, unless otherwise noted.

SYMBOL	PARAMETER	RATING	UNIT
V_{IN}	IN Voltage	-0.3 to 36	V
V_{OUT}	OUT Voltage	-0.3 to 28	V
I_{OUT_MAX}	Maximum Continuous Current	2.5(MAX)	A
I_{OUT_PEAK}	Maximum Peak Current	4	A
P_D	Power Dissipation at $T_A=+70^{\circ}\text{C}$	500	mW
$T_{J(MAX)}$	Junction Temperature	150	$^{\circ}\text{C}$
T_{STG}	Storage Temperature	-65 to 150	$^{\circ}\text{C}$
T_{SDR}	Soldering Temperature (Reflow)	260	$^{\circ}\text{C}$
V_{ESD}	HBM	± 2000	V

NOTE 1: Stresses beyond those listed under Absolute Maximum Ratings may cause permanent damage to the device. These are stress ratings only, which do not imply functional operation of the device at these or any other conditions beyond those indicated under Recommended Operating Conditions. Exposure to absolute-maximum-rated conditions for extended periods may affect device reliability.

8. Recommended Operating Conditions

SYMBOL	PARAMETER	MIN	MAX	UNIT
V_{IN}	Input Voltage	3	36	V
T_A	Operating Ambient Temperature	-40	85	$^{\circ}\text{C}$

9. Electrical Characteristics

($V_{IN}=5\text{ V}$, $C_{IN}=1\mu\text{F}$, $C_{OUT}=1\mu\text{F}$, $T_A=25^\circ\text{C}$, unless otherwise noted)

SYMBOL	PARAMETER	TEST CONDITIONS	MIN	TYP	MAX	UNIT
Basic Operation						
V_{IN}	Input Voltage		3		36	V
I_{IN}	V_{IN} Quiescent Current	$V_{IN}=5\text{V}$, OUT Floating		110		μA
R_{ON}	On-Resistance of Switch IN-OUT	$V_{IN}=5\text{V}$, $I_{OUT}=1\text{A}$		110		$\text{m}\Omega$
V_{OVLO}	OVP Trip Level	V_{IN} Rising		10		V
$V_{OVLO-HYS}$	Hysteresis of OVP Trip Level	V_{IN} Falling		0.15		V
V_{UVLO_R}	Under Voltage Lockout Threshold	V_{IN} Rising		2.5		V
Over Temperature Protection (OTP)						
T_{SD}	Thermal Shutdown	$V_{IN}=5\text{V}$		155		$^\circ\text{C}$
ΔT_{SD}	Thermal Shutdown Hysteresis	$V_{IN}=5\text{V}$		20		$^\circ\text{C}$
Dynamic Characteristics						
t_{DEB}	Debounce Time	Time from $2.5\text{V} < V_{IN} < V_{OVLO}$ to $V_{OUT} = 10\%$ of V_{IN}		16		ms
t_{ON}	Switch Turn-on Time	$R_L=100\Omega$, V_{OUT} from $10\%V_{IN}$ to $90\%V_{IN}$		0.3		ms
t_{ON_ALL}	Output Power-on Time	Time from $2.5\text{V} < V_{IN} < V_{OVLO}$ to $V_{OUT}=90\%$ of V_{IN}		16.3		ms
$t_{OFF_RES}^{[2]}$	Switch Turn-off Response Time	$R_L=100\Omega$, $C_L=0\mu\text{F}$, $V_{IN} > V_{OVLO}$ to V_{OUT} Stop Rising		100	500	ns
Over Current Protection (OCP)						
I_{OCP}	Overcurrent protection		2.5	3.1		A

SYMBOL	PARAMETER	TEST CONDITIONS	MIN	TYP	MAX	UNIT
$t_{OCP}^{[3]}$	OCP debounce time			30		ms
$t_{REC_OCP}^{[3]}$	OCP recovery time			1		s

NOTE 2: Guaranteed by design. The Switch Turn-off Response Time may vary with respect to V_{IN} slew rate.

NOTE 3: Guaranteed by design.

10. Timing Diagram

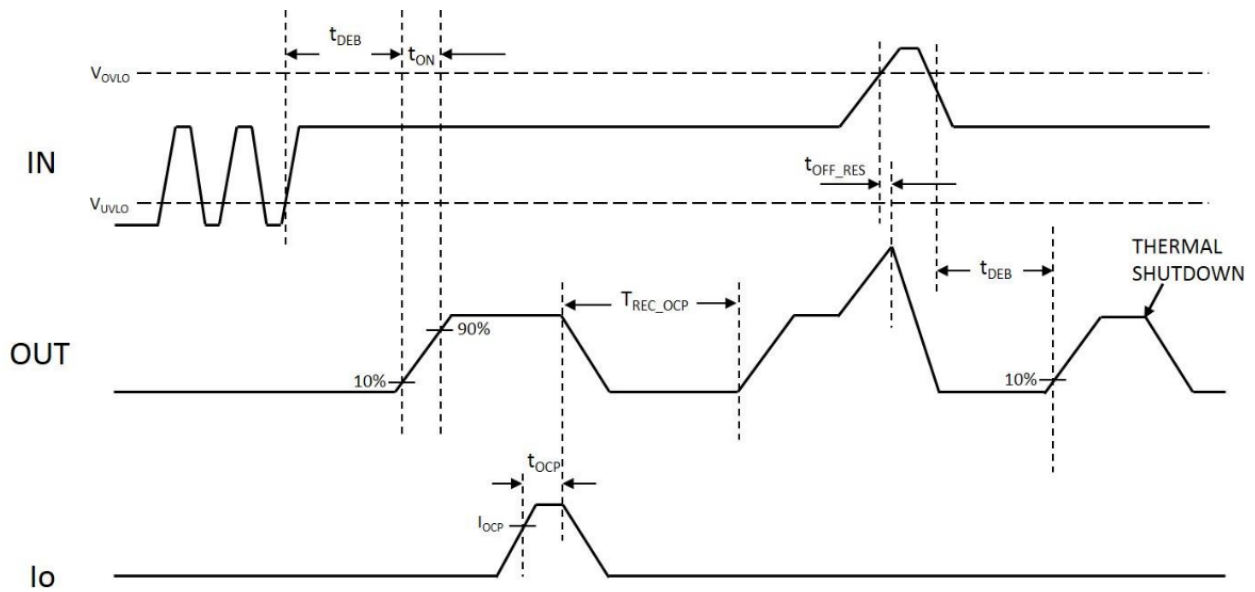

11. Function Description

11.1 Overview

The WP1437 with overvoltage protection features a low 110mΩ (Typ.) $R_{DS(ON)}$ of internal FET and protects low-voltage systems against voltage faults up to 36V_{DC}. If the V_{IN} exceeds 10V, or input current exceeds 2.5A, the internal FET is quickly turned off to prevent the downstream components from damage.

The internal FET turns off when the junction temperature exceeds 155°C (Typ.). The device exits thermal shutdown after the junction is cooled down by 20°C (Typ.).

11.2 Block Diagram

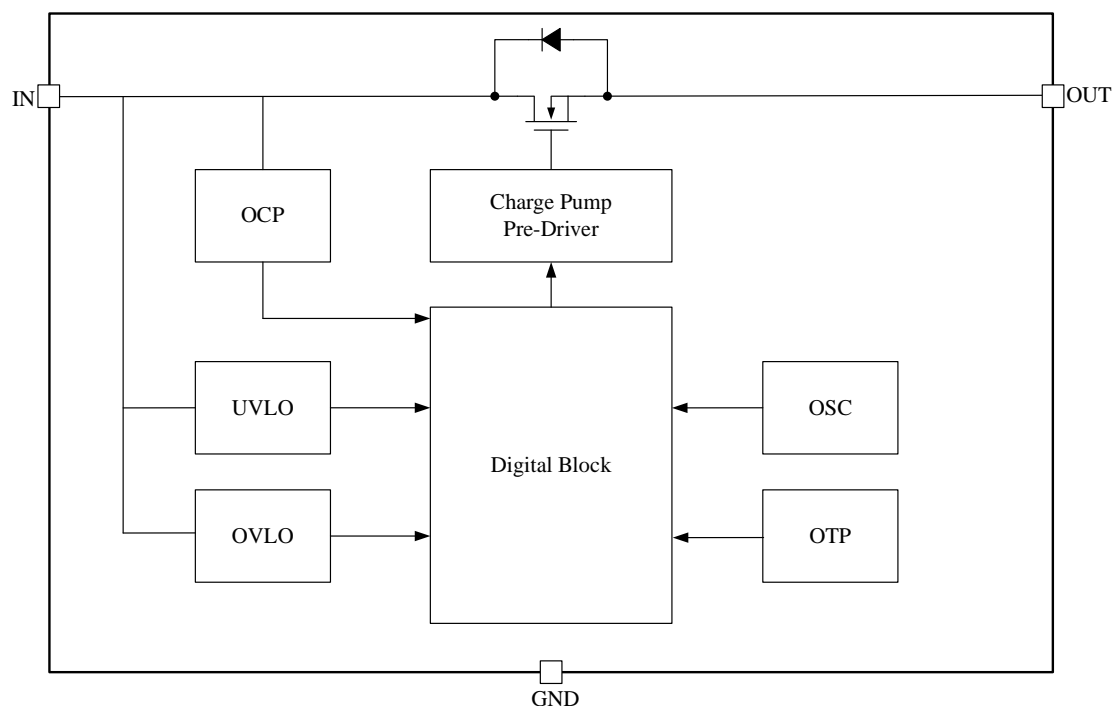

11.3 Feature Description

11.3.1 Under Voltage Lock Out (UVLO)

The under-voltage lockout (UVLO) circuits disable the WP1437 until the input voltage reaches the UVLO turn-on threshold.

11.3.2 Over Temperature Protection (OTP)

The WP1437 monitors its own internal temperature to prevent thermal failures. The device turns off the internal FET when the junction temperature reaches 155°C. The device will resume after the junction is cooled down by 20°C.

11.3.3 Input Over Voltage Protection (OVP)

If the input voltage exceeds the WP1437 rising trip level, the switch will be turned off in about 100ns. The switch will remain off until V_{IN} falls below the WP1437 falling trip level.

12. Application and Implementation

12.1 Selection of Input Capacitor

To limit the voltage drops on the input supply caused by transient inrush current, a capacitor must be placed between the IN and GND pins.

12.2 Selection of Output Capacitor

A capacitor should be placed between the OUT and GND pins.

13. Evaluation Modules

Evaluation Modules (EVMs) are available to help evaluate initial circuit performance. We have evaluation modules for different packages, you can contact us to get the evaluation module or schematic.

The module names are listed in the following table.

Name	Package	Evaluation Module
WP1437	SOT23-6L	EFUSES_EVM_V1.0 SOT23-6_WP1437

Layout Guidelines

For best performance, all traces should be as short as possible, the input and output capacitors should be placed close to the device to minimize the effects that parasitic trace inductances may have on normal and short-circuit operation. Using wide traces for V_{IN} , V_{OUT} , and GND will help minimize parasitic electrical effects and minimize the case to ambient thermal impedance.

Layout Example

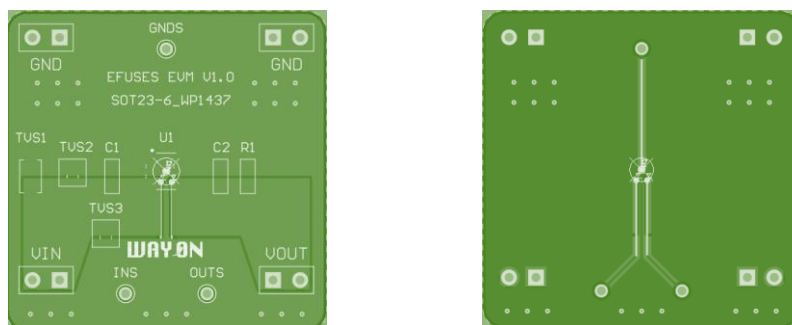

14. Naming Conventions

WP AB CC-DDD E

- WP:** WAYON Protection IC;
- A:** Product Category –1: E-fuse;
- B:** Maximum Output Current – 4: <4A;
- CC:** Serial number;
- DDD:** Package – A60: SOT23-6L;
- E:** R-Reel & T-tube;

15. Package Information

SOT23-6L

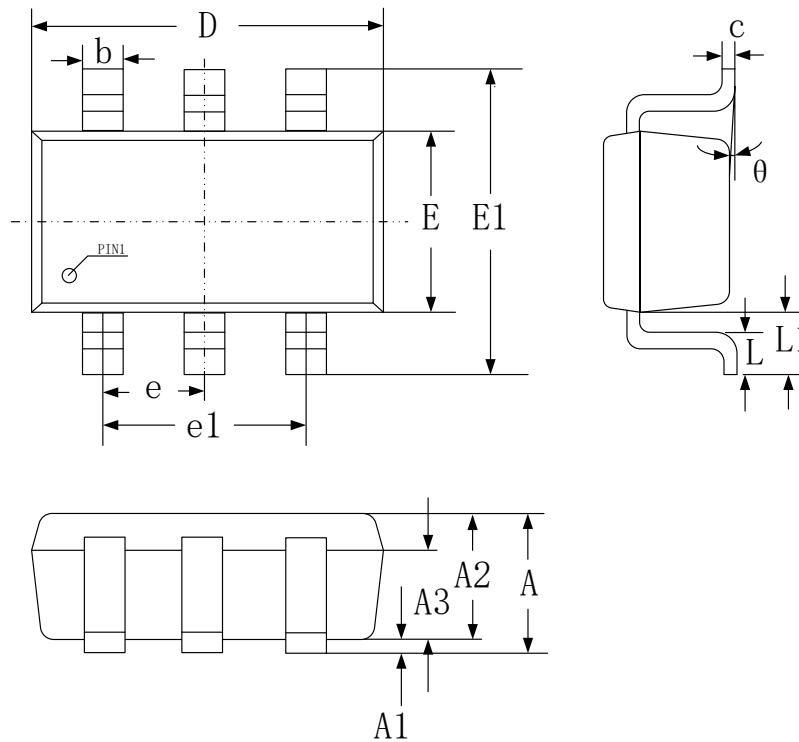

SYMBOL	DIMENSIONS IN MILLIMETERS		
	MIN	NOM	MAX
A	-	-	1.25
A1	0.00	-	0.15
A2	1.00	1.10	1.20
A3	0.575	0.65	0.725
b	0.325	-	0.5
c	0.1	-	0.2
D	2.82	2.92	3.02
E	1.50	1.60	1.70
E1	2.60	2.80	3.00
e	0.925	0.95	0.975
e1	1.90 BSC		
L1	0.59 REF		
L	0.35	0.45	0.60
θ	0°		8°

16. Ordering Information

PART NUMBER	PACKAGE	PACKING QUANTITY	MARKING*
WP1437-A60R	SOT23-6L	3k/Reel	WP1437 XXXX

* XXXX is variable.

Contact Information

No.1001, Shiwan(7) Road, Pudong District, Shanghai, P.R.China.201202

Tel: 86-21-68960674 Fax: 86-21-50757680 Email: market@way-on.com

WAYON website: <http://www.way-on.com>

For additional information, please contact your local Sales Representative.

WAYON® is registered trademark of Wayon Corporation.

Specifications are subject to change without notice.

The device characteristics and parameters in this data sheet can and do vary in different applications and actual device performance may vary over time.

Users should verify actual device performance in their specific applications.

Product Specification Statement

- The product specification aims to provide users with a reference regarding various product parameters, performance, and usage. It presents certain aspects of the product's performance in graphical form and is intended solely for users to select product and make product comparisons, enabling users to better understand and evaluate the characteristics and advantages of the product. It does not constitute any commitment, warranty, or guarantee.
- The product parameters described in the product specification are numerical values, characteristics, and functions obtained through actual testing or theoretical calculations of the product in an independent or ideal state. Due to the complexity of product applications and variations in test conditions and equipment, there may be slight fluctuations in parameter test values. WAYON shall not guarantee that the actual performance of the product when installed in the customer's system or equipment will be entirely consistent with the product specification, especially concerning dynamic parameters. It is recommended that users consult with professionals for product selection and system design. Users should also thoroughly validate and assess whether the actual parameters and performance when installed in their respective systems or equipment meet their requirements or expectations. Additionally, users should exercise caution in verifying product compatibility issues, and WAYON assumes no responsibility for the application of the product.
- WAYON strives to provide accurate and up-to-date information to the best of our ability. However, due to technical, human, or other reasons, WAYON cannot guarantee that the information provided in the product specification is entirely accurate and error-free. WAYON shall not be held responsible for any losses or damages resulting from the use or reliance on any information in these product specifications. WAYON reserves the right to revise or update the product specification and the products at any time without prior notice, and the user's continued use of the product specification is considered an acceptance of these revisions and updates. Prior to purchasing and using the product, users should verify the above information with WAYON to ensure that the product specification is the most current, effective, and complete. If users are particularly concerned about product parameters, please consult WAYON in detail or request relevant product test reports. Any data not explicitly mentioned in the product specification shall be subject to separate agreement.
- Users are advised to pay attention to the parameter limit values specified in the product specification and maintain a certain margin in design or application to ensure that the product does not exceed the parameter limit values defined in the product specification. This precaution should be taken to avoid exceeding one or more of the limit values, which may result in permanent irreversible damage to the product, ultimately affecting the quality and reliability of the system or equipment.
- The design of the product is intended to meet civilian needs and is not guaranteed for use in harsh environments or precision equipment. It is not recommended for use in systems or equipment such as medical devices, aircraft, nuclear power, and similar systems, where failures in these systems or equipment could reasonably be expected to result in personal injury. WAYON shall assume no responsibility for any consequences resulting from such usage.
- Users should also comply with relevant laws, regulations, policies, and standards when using the product specification. Users are responsible for the risks and liabilities arising from the use of the product specification and must ensure that it is not used for illegal purposes. Additionally, users should respect the intellectual property rights related to the product specification and refrain from infringing upon any third-party legal rights. WAYON shall assume no responsibility for any disputes or controversies arising from the above-mentioned issues in any form.